

MEMS-BASED SYSTEMS SOLUTIONS

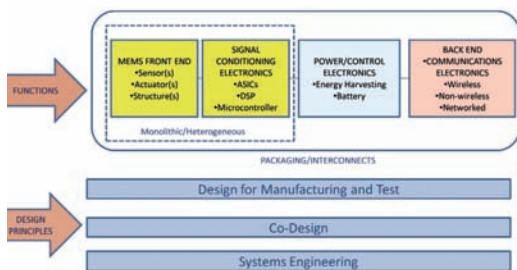

Figure 1

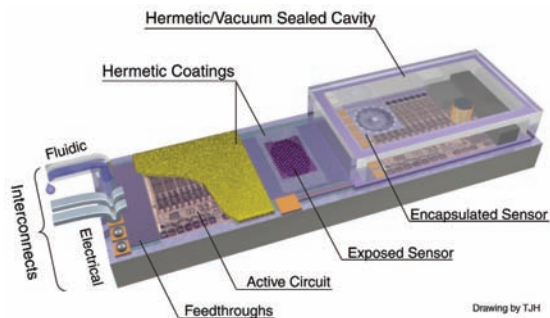

Figure 2



Figure 3

THINK OUTSIDE THE CHIP... MEMS-BASED SYSTEMS

Roger Grace, President Roger Grace Associates

INTRODUCTION

MEMS is an acronym for micro-electro-mechanical Systems, however most 'MEMS' implementations to date have not been systems at all but rather devices. This article addresses the creation of solutions that are enabled by MEMS. I have named this 'MEMS-based systems solutions' or MBSS. These systems use front-end MEMS devices either one or a combination of many sensors, actuators and/or structures that additionally use the functionalities of many other devices including signal conditioning ASICs, DSP with embedded software, energy creation and storage, and finally networking communications functions. All of these functions need to be interconnected and contained in a small, robust, low-cost package that has the ability to be tested in a high-throughput fashion. The concepts of classical system engineering include bringing the design team together from day one; co-design principles that acknowledge the interaction of the MEMS, other electronics and packaging; reliability analysis and finally the embracing of design for manufacturing and test are the principles that underlie this approach (Figure 1). This highly integrated solution is driven by the specific application. Figure 2 is an illustration of a good example of the concept of an MBSS developed by the Wireless Integrated MicroSystems Center (WIMS) at the University of Michigan

(www.wimserc.org). This concept can also be referred to as 'Smart Systems Integration' which is also the topic of the annual conference bearing its name, held in Europe in March.

APPROACHES TO MEMS-BASED SYSTEMS SOLUTIONS APPLICATIONS

Our recently conducted market research on MBSS approaches has established that they can fall into two categories: category one has an in-house developed 'enabling engine' that drives the solution. As an example, a high sensitivity MEMS accelerometer created by HP is the enabler for a wireless autonomous sensor network for seismic oil and gas exploration applications. Other examples of this approach include Polychromix, the creator of a handheld optical near infrared (NIR) spectrometer, the microPhazer (Figure 3) and C2V which has created a micro fluidic gas chromatograph. Both organizations have been recently acquired by Thermo Fisher. The micro Phazer uses an in-house developed Silicon Michelson NIR spectrometer built using the Sandia National Laboratory SUMMiT polysilicon process. All of the parts of the handheld device were designed in-house or specified including the very sophisticated application algorithms and integrated to create the handheld instrument. We consider portable analytical instruments to

hold great promise to help propel MEMS-based spectrometers and chromatographs into the laboratory diagnostics and medical point of care application sectors. Strategic Decisions International has estimated the total worldwide market for analytical and life sciences instruments to be approximately \$35 billion (US) in 2008 with a compounded annual growth rate (CAGR) of 5-6%. Currently the majority of this market is for benchtop instruments. However the report states that the portable and handheld market is expected to grow in the high teens annually over the next five years.

The other approach, 'commoditized integration' uses standard off-the-shelf MEMS devices in conjunction with ASICs /DSPs with proprietary application software and proprietary packaging to create a solution. Examples of this approach are Schrader Electronics with its automotive tire pressure monitoring systems using standard off-the-shelf pressure and motion sensors, Hillcrest Laboratories and Movea in their human-machine interface devices for gesture recognition using MEMS accelerometers and gyros and MEMSIC using various sensors for its bridge structural monitoring and avionics, marine and off-road vehicle navigation system (Figure 4). The value added to these 'commoditized' solutions is the knowledge of the application and the ability to successfully accomplish intelligent systems

Figure 1: Courtesy — Roger Grace Associates. For a MBSS approach to be successful it takes a broad interdisciplinary team to work together from the onset of the project. The system-based solution embraces system co-design, reliability analysis and design for manufacturing and test disciplines. **Figure 2:** MEMS-Based Systems Solutions (MBSS) demand that designers 'think outside the chip'. While the MEMS chip(s) is/are necessary requirement(s) of the solution, care must be given to address all the other system components including the interconnects and final package. Courtesy — University of Michigan Wireless Integrates MicroSystems Center. **Figure 3:** Courtesy — Thermo Fisher. The microPhazir handheld NIR Michelson spectrometer is a fully integrated analytical instrument that provides measurement accuracies comparable to laboratory benchtop systems for process quality control monitoring, environmental monitoring and homeland security applications. **Figure 4:** Courtesy — MEMSIC. Attitude Heading and Reference Systems (AHRS) consists of off-the-shelf MEMS inertial sensors combined with proprietary algorithm — embedded DSP and stress reducing packaging mounted on a PC board. **Figure 5:** Courtesy — ePack. A schematic representation of ePack's patented environmental resistant package (ERP) which increases performance to MEMS accelerometers, gyros and system timing product resonators through mechanical and thermal isolation design concepts.

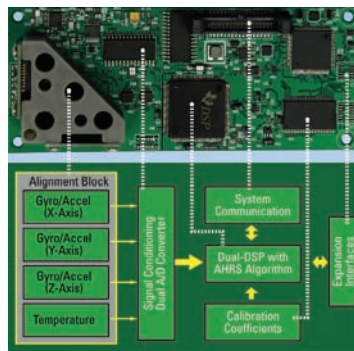

Figure 4

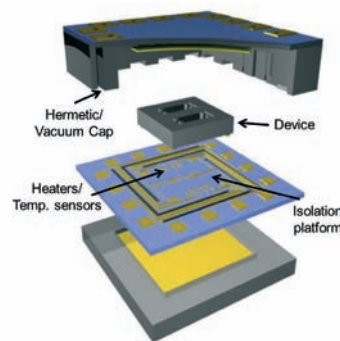

Figure 5

SOLUTIONS

integration and provide software programming specific to the application. All of this is neatly packaged in a low-cost and robust fashion.

DRIVERS FOR ADOPTION OF MBSS

There are a number of drivers, both technical and business-related that we believe will make the adoption of MBSS a major business success for MEMS in the very near future. The most significant of these is cost, availability, market expansion and the need for product differentiation and optimization of gross margin on the part of the supplier of the solution. The maturing or commoditization of MEMS devices has enabled large volume applications including mobile phones and games to adopt these low-cost devices as integral to their strategy of providing many more functions, higher performance and efficiency to their phones. This facilitates the creation of product differentiation between phone suppliers. Additionally, the necessity of the MEMS device to work in conjunction with a signal processor in the form of an ASIC and/or DSP which are commercially available from many vendors providing solution designers with a wide choice of partners. Therefore, the barriers to entering the MBSS market from a commoditized approach can be much lower than that of the enabling engine approach.

PACKAGING

It is well known that packaging and testing of MEMS devices can consume up to 70% of the total cost of the device. Additionally, since MEMS devices tend to be mechanical in nature, they can be affected by package stresses created through thermal mismatching of the sensor, the electronics and the package. The solution to minimize this problem is to mechanically and thermally isolate the MEMS device from the package. A novel approach to this has been created by ePack. Here the package which is made from MEMS-based processes minimizes factors including package stress and material property changes associated with temperature change by mechanically isolating the sensor from the package and the shock and vibration environment in addition to creating the condition of a low and fixed pressure in which the sensor operates virtually isolating the sensor from the environment (Figure 5).

CO-DESIGN

As an extension to the issue of MEMS device and package interaction, the concept of designing the package simultaneously and considering the package has become an approach that has been adopted by many MEMS developers. Co-design is the name given to this approach and a number of MEMS software design providers offer this solution.

SoftMEMS has created design tools that allow the designer to create models for the MEMS devices that are directly useable electronics simulations by circuit designers to simulate sensing amplifiers, control electronics and temperature compensation circuitry combined with the MEMS device. The models encapsulate coupled mechanical, thermal and fluidic effects so that these effects are present during electronic simulation which is important as overall system timing is affected by the mechanical movement of MEMS devices which in turn depends on physical mechanisms such as damping. Co-design tools also enable circuit designers, MEMS designers and package designers to include package electrical performance parameters in the MEMS and circuit simulations to minimize unwanted electrical and parasitic, and to maximize energy efficiency.

INTERFACE ELECTRONICS

The interface electronics, which is frequently an applications-specific integrated circuit (ASIC), is multi-functional. It must translate the MEMS output signal into something useful and it must (often) stimulate the sensor in order to make it more sensitive to the input. Translation requirements may include signal conditioning, filtering, calibration, A-to-D conversion, and a communications protocol-SPI, PWM, etc.

FEATURE mems-based systems

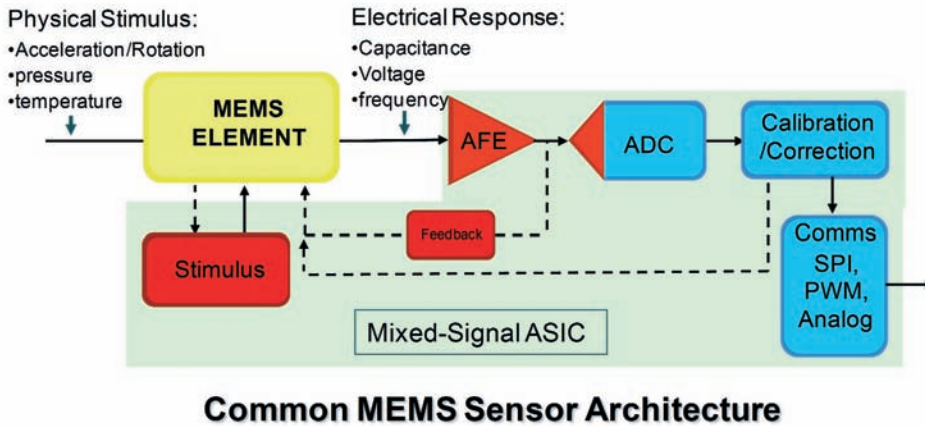

Figure 6: Courtesy — Intrinsic. Custom mixed-signal ASIC (shown in green background) sits between the MEMS device and the system. Stimulus and translation complexities require innovative and robust ASIC designs to maximize performance.

Stimulus may include low or high voltage capacitive drive with open loop or closed loop control, switching, frequency mixing and frequency generation. As a result, use of custom mixed signal ASICs has gone from a high volume cost savings option to an absolute performance necessity (Figure 6). Intrinsic is one of a number of companies providing ASIC

design and development services to MEMS device suppliers to create MBSS solutions.

CONCLUSIONS

MBSS has existed for many years, however the current proliferation of this approach is being fueled from the technology push perspective by the availability of low-cost MEMS devices and

signal conditioning ASICs and DSPs as well as packaging and high throughput testing. The need for gesture recognition in games, toys, computer peripherals (mice), medical, sports and fitness bodes well for this approach. Additionally, as the need to better understand the quality of food and water as well as the chemical and biological composition of many substances to enhance society's quality of life including point of care diagnostics, MBSS for spectrometers and chromatographs for handheld instruments will fuel the 'enabling engine' concept. However, we believe that the ultimate forcing factor to the adoption of MBSS will be the need on the part of the solution provider to create well defined and defensible product differentiation and higher profit margins vis-à-vis higher levels of integration and value added. The embracing of a MBSS approach can create uncontested approaches to a customer's application and fulfil the requirements of a 'blue ocean market strategy' versus having to assume a less favorable 'red ocean market strategy' currently associated with highly competitive, low gross margin MEMS devices.

BUSINESS DEVELOPMENT & STRATEGIC MARKETING CONSULTING

Need to **expand** your business?

For over 25 years, **Roger Grace Associates** has helped a broad spectrum of international high technology clients successfully expand their business through...

- Understanding the market through in depth custom market research
- Developing and launching new products
- Entering new markets
- Creating and executing strategic marketing communications programs
- Developing distribution channels
- Creating business alliances
- Conducting due diligence
- Developing new business
- Creating and executing branding and positioning campaigns

We have worked successfully with our many clients in the MEMS, Nanotechnology, Semiconductor, Sensors and Capital Equipment markets to plan and execute high R-O-I programs to create new business opportunities.

Learn how you can benefit from our extensive industry experience, knowledge and proven track record and **expand your business.**

Visit us at www.rgrace.com

ROGER GRACE ASSOCIATES
MARKETING COUNSEL